

CORNELL PUMP LLC

OIL & GAS



OIL & GAS PUMPS



OIL & GAS MARKET

From upstream exploration and production to midstream transportation and downstream refining, our pumps deliver exceptional performance and durability. Our pumps are designed to handle the demanding conditions and rigorous oil and gas operations requirements. With high-pressure capabilities, efficient solids handling, and corrosion-resistant materials, our pumps are built to withstand harsh environments and abrasive fluids in the oil and gas sector.

OIL & GAS PUMP QUALITIES

HIGH EFFICIENCY

Cornell has produced highly efficient pumps since 1946; many of our configurations lead the industry with efficiencies above 87 percent. With fuel prices at record levels, Cornell pump's high energy efficiency stretch your money further on-site. Cornell manufactures more than 65 clear liquid and non-clog pumps that meet or exceed optimum efficiency standards for centrifugal pumps. Many Cornell installations save users significant costs through increased efficiency. That's money you can put back into your operation! The bottom line – Cornell Oil and Gas pumps cost less to operate.

THICKER, SLEEVED SHAFTS

The Alloy steel shaft is more than 25% thicker than most other competitors. This allows the shaft to work under greater stress and still perform well. The sleeved shaft prevents materials from flowing back into the pump and prolongs the shaft and seal life. Sleeves are standard on Cornell Pumps—if available from a competitor, they are often expensive options. 420HT sleeve shafts are available for abrasive materials.

SOLIDS HANDLING

Cornell's two- and three-port enclosed impellers are designed to handle large solids and maintain exceptional hydraulic efficiencies. Cornell's Delta™ style impeller handles stringy materials and heavy sludge for low- to medium-head applications. The three- or four-vane, semi-open impeller generates a cutting action to handle concentrated slurries for high-head applications.

Cornell offers a wide range of Solids Handling pumps, from 1.25" through 30" discharge size, to handle the most challenging oil and gas applications. Cornell Solids Handling pumps can be found in a wide range of applications in the Municipal, Agricultural, and Industrial markets and are available in various mounting configurations, including Close-Coupled, SAE Engine, Horizontal, and Vertical mounted.

SILICON-CARBIDE SEAL

An externally lubricated mechanical seal is standard. Seal can be run dry on high vacuum even when pumping highly abrasive materials.

OIL & GAS APPLICATION STORY

NEW PUMP MODELS MAXIMIZE PRODUCTION AND MINIMIZE COST

Richard Holton (CID), Southeast Regional Manager

A Gulf Coast-based pump supplier of Cornell, one of the leading suppliers to the shale fracturing industry, had a customer who faced piping hydraulic fracturing water transfer with multiple pumps. New Cornell pumps helped pump more efficiently with lower fuel costs.

The company operated six miles of twin 8" pipeline with 100' of positive elevation change over the length of the channel. The company needed to pump 100 barrels of water per minute (4200 GPM) through the pipeline to supply the water.

The water transfer company had nine 6NHTBs on site to do the job. Three 6NHTBs were sitting at the water source as the supply pumps. Spaced along the twin 8" pipelines were six more 6NHTBs at various intervals to boost the pressure. This required significantly more labor to initially set, maintain, and monitor nine pumps than the solution pumps.

After Cornell and the dealer analyzed the specifications for the system, an option was recommended that cut the number of pumps needed to three. The solution was to place an 8NHTH at the water as a supply pump and one 6822MX on each 8" pipeline as booster pumps. Not only did this cut the number of pumps by two-thirds, but it also drastically reduced diesel fuel consumption on the project.

The 6822MX is part of Cornell's high-head "MX" line of mining pumps released in 2010. The "MX" line of pumps boasts industry-leading performance with flows up to 8,000 GPM and heads up to 800' TDH. They are available in 2"-8" discharge sizes and include ductile iron casings with CA6NM impellers.

While the 8NHTH may not be a new pump for Cornell, it is relatively new to the oilfields. It is a 10X8 pump that boasts a maximum 20.50" impeller with a max flow of 8400 GPM and a shutoff head of 460. This impressively solid pump has a wide flow range with excellent efficiencies.

Since being introduced into the oilfields by the supplier in 2011, the "MX" pumps and the 8NHTH have substantially changed how many of these problematic projects are approached. Stacking large numbers of pumps to do long pipe runs or drastic elevation changes is no longer necessary. These pumps have become staples of many oilfield companies' product offerings.

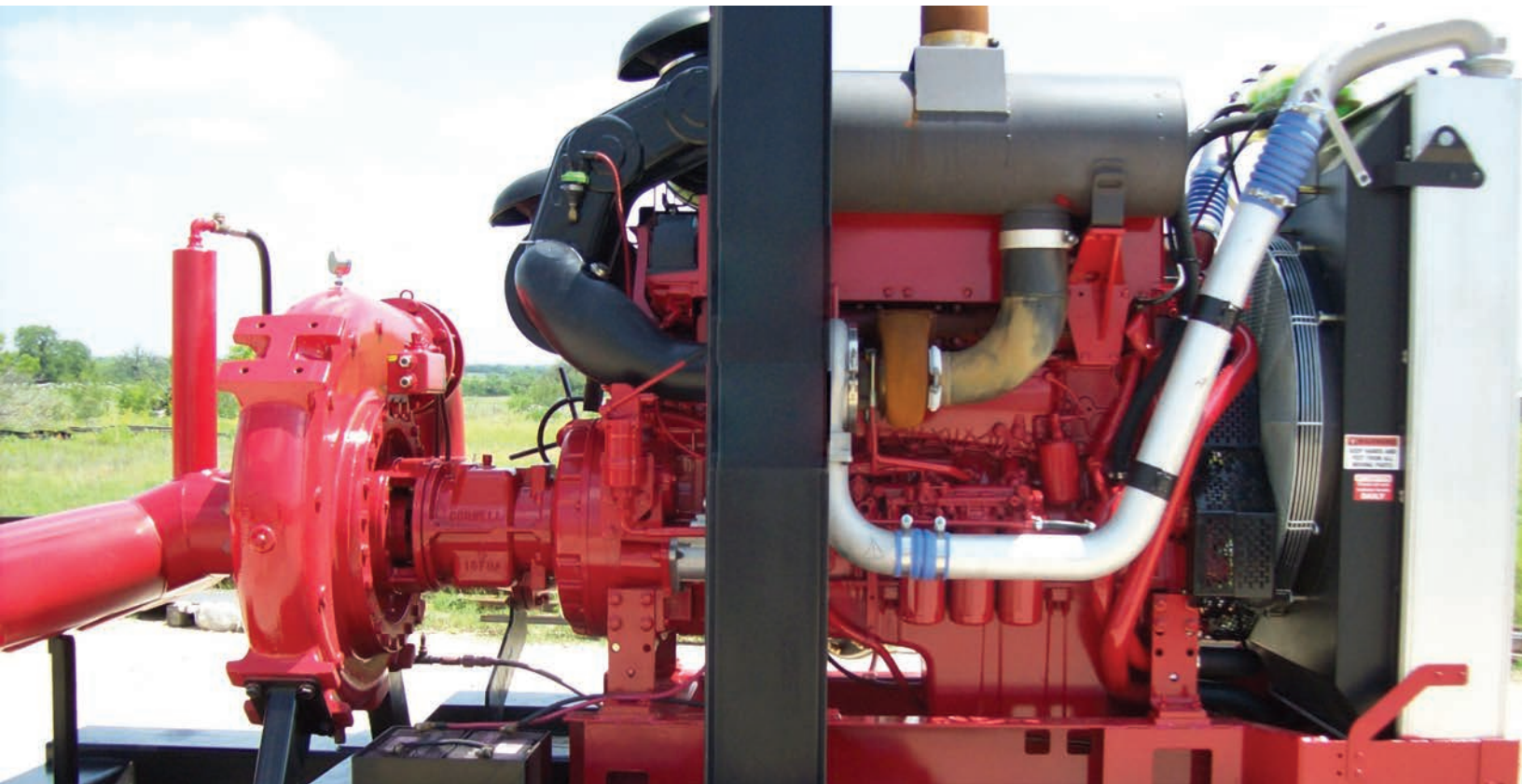

OIL & GAS PUMPS

CORNELL PUMPS FOR THE OIL & GAS INDUSTRIES

Cornell Pump Company produces extra heavy wall thickness pumps featuring industry-leading efficiency. We make water distribution pumps in the most popular sizes from 3" to 8", with up to 28 feet of suction, 475 feet of head, and 7000 GPM flow. Cornell's series of pump lines for oil and gas exploration, application dewatering, and hydraulic fracturing follows:



OIL & GAS PUMPS



CUTTER PUMPS

Winner of the 2012 Innovative Product of the Year award from Pumps & Systems magazine, the cutter is designed to break up clogs and reduce ragging. Oil and gas operations use it to remove wastewater from the site. In applications, its ability to pass through solids saves up to \$31,000 per installation per year on maintenance costs.



SP SERIES

Cornell Pump Company's SP Series Slurry pump brings patented Cycloseal technology to the oil and gas industry. Adding to the diverse range of O&G dewatering pumps, The SP Series Slurry pump offers a Cornell solution to abrasive applications throughout the mill process. The SP Series incorporates a double-casing design with replaceable liners, chrome iron, and rubber impellers. The patented Cornell Cycloseal® includes a unique deflector vane back plate and expeller to offer a reliable, single mechanical seal design, even in the most severe operating conditions. The optional Run-Dry™ reservoir protects without the need for flush water.



MP SERIES

MP Series Mining Pumps are designed for coarse abrasives. Cornell Pump Company's MP Mining Pump Series brings patented Cycloseal® technology to the oil and gas industry. Adding to Cornell's diverse range of dewatering pumps, MP series mining pumps offer high operating pressures. They are designed for coarse abrasive slurry applications such as sand, gravel, coal, manure, and mine dewatering.



MX SERIES

High pumps featuring a four-vane enclosed impeller design handle solids up to 2". A slurry pump with up to 75 percent efficiencies, the MX series is designed for high operating pressures and flow requirements. Dependable, high-quality construction sets it apart from other slurry pumps—CA6NM impellers are standard on the pumps—available in horizontal frame and SAE mount configurations.



SM SERIES

The SM Series of pumps from Cornell is designed to handle a wide range of slurry applications and are especially effective for series pumping. These pumps are robust and durable with their unlined high chrome white iron wet ends. They are equipped with Cycloguard® and Cycloseal® innovations that extend their seal life and keep solids away from the seal area for reduced wear. The pumps are designed to operate at a maximum working pressure of 600 PSI.

HYDRAULIC SUBMERSIBLES

A premium pump with hydraulic efficiencies of 76 to 80 percent BEP, the pumps handle 3" or larger solids, with total dynamic head of up to 360 feet and up to 7,000 GPM. Hydraulic submersibles are designed for mining, oil/gas, industrial, flood control, and agricultural applications; standard construction is a class 30 cast iron, with optional construction in 316SS, CD4MCu, and ductile iron.



OIL & GAS PUMPS



STX SERIES

The Cornell Pump Company's STX pump series is a robust and efficient line of self-priming centrifugal pumps designed to handle various liquids, including solids-laden and abrasive fluids. With a focus on durability and reliability, the STX series features innovative impeller and volute designs that enable smooth and clog-resistant operation. These pumps are well-suited for agriculture, municipal, industrial, and rental applications, offering a dependable solution for fluid transfer and handling challenges.

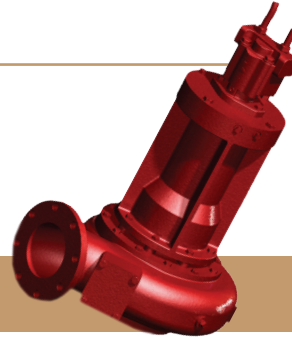

SUBMERSIBLE

At Cornell, we understand the need for reliability, durability, and efficiency. This is why we have coupled our pumps with the most reliable and durable submersible motors on the market. Cornell motors are FM-approved and suitable for Class I, Division I, Group C & D, explosion-proof service, and are inverter duty. Non-wicking, permanently numbered leads are potted into a separate cable cap assembly, preventing leakage to the stator.

Thermostats protect Cornell motors and utilize class F insulation. Dual moisture probes are installed for the early detection of seal failure. Capacities from 80 GPM to 15,000 GPM and heads from 10 feet to 400 feet give Cornell a clear performance advantage.



ADDITIONAL OPTIONS

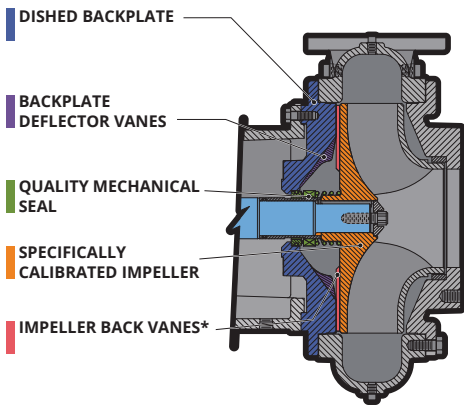

CYCLOSEAL®

Cornell's Cycloseal is an ideal solution for water and wastewater applications. This patented technology is a self-contained single mechanical seal with a dished backplate, eliminating the need for an external flushing system or water flush line. The configuration includes stationary deflector vanes, contoured impeller back vanes, and a dished backplate that create pressure gradients, moving solids and vapor away from the seal faces. Cycloseal can last up to ten times longer than a typical mechanical seal.

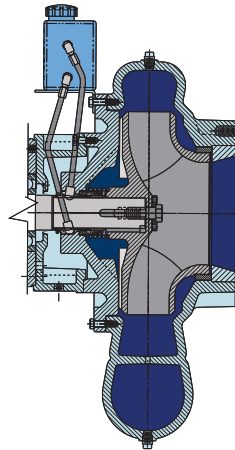

RUN-DRY™

Cornell has developed the Run-Dry system to prevent pump damage during dry operating conditions. This system features an auxiliary gland and oil reservoir that keeps seal faces lubricated during priming, re-priming, or standby operation. The gland is connected to a lubricant reservoir, allowing continuous circulation and cooling of the lubricant and seal faces. The Run-Dry system is ideal for applications where dry operation is possible.

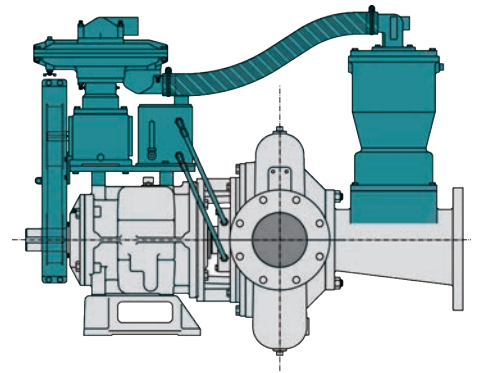

REDI-PRIME®

Cornell's Redi-Prime pumps have oversized suctions that increase flow, decrease friction losses, and enhance suction lift. The priming system is environmentally friendly, featuring a positive sealing float box and a diaphragm vacuum pump that prevents water carry-over and contamination. The Redi-Prime system can be easily installed on most Cornell pumps, providing suction lifts of up to 28 feet, heads up to 800 feet, and flow rates surpassing 20,000 GPM.

CORNELL PULSE™



- CONNECTS VIA SHORT-RANGE WIRELESS
- PROVIDES A SNAPSHOT OF OPERATION
- INCLUDED ON ALL NEW CORNELL PUMPS*
- RETROFITTABLE TO OLDER PUMPS OR OTHER EQUIPMENT

LEADING-EDGE REAL TIME SNAPSHOT

Cornell Pulse is a new method to measure pump temperature and vibration in real time. The device is a small wireless unit, less than 2" in circumference, which is mounted on the pump and takes readings when prompted by the user via a mobile app. The app can be used on phones and tablets and allows detection of common pump issues if the user keeps track of the readings. Pulse is designed to withstand tough

wash-down conditions and can last up to five years with daily measurements (more frequent measurements use battery power and reduce service life.)



DOWNLOAD THE PULSE APP



AGRICULTURE



FOOD PROCESS



INDUSTRIAL



MINING



MUNICIPAL



WATER TRANSFER



REFRIGERATION



CONSTRUCTION

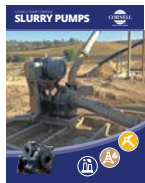

SLURRY



SLURRY SM



MANURE

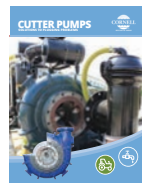

CUTTERS



SELF PRIMING

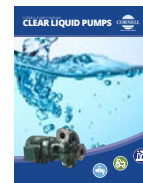

CLEAR LIQUIDS



MX SERIES



N SERIES

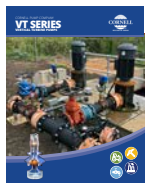

CYCLONE™

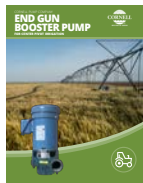

EDGE™



HYDRAULIC SUBS



IMMERSIBLE



CD4MCU

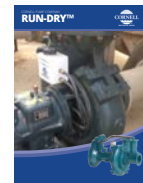

RUN-DRY™

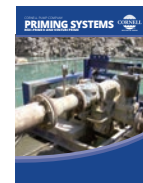

PRIMING SYSTEMS



CYCLOSEAL®

Cycloseal® and Redi-Prime® are Registered Trademarks of Cornell Pump Company.

Cornell pumps and products are the subject of one or more of the following U.S. and foreign patents:

6,074,554; 6,036,434; 6,079,958; 6,309,169; 6,104,949.

23 - OL - BR - 001

CORNELLPUMP.COM
©2023 CORNELL PUMP COMPANY

AUTHORIZED CORNELL PUMP DISTRIBUTOR



Cornell Pump Company
Clackamas, Oregon, USA
P: +1 (503) 653-0330
F: +1 (503) 653-0338