

10NHTB-F

DATA SHEET

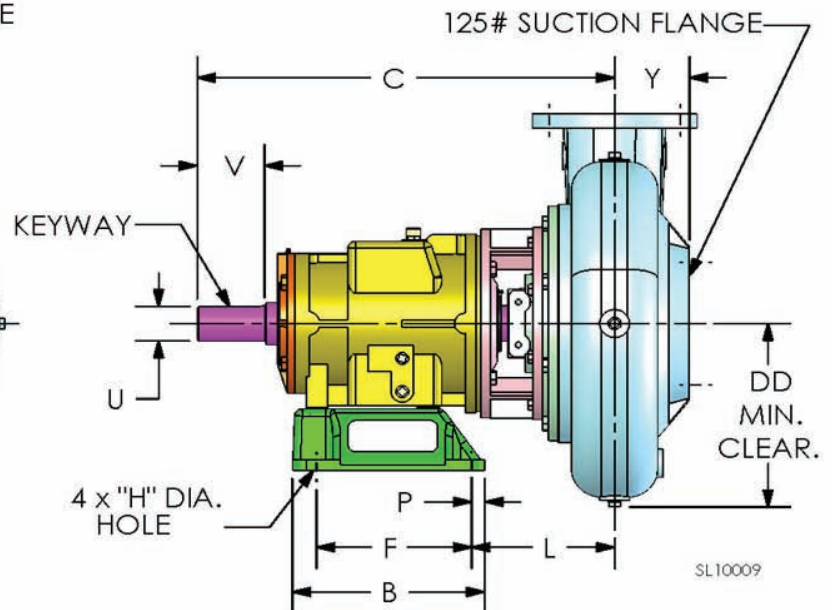

- **Size:** 10NHTB - 10" discharge x 12" suction with 125# cast iron flanges
- **Casing:** Cast Iron
- **Impeller:** Enclosed - 2 vane. Handles 4.75" diameter solids
- **Wear Rings:** Replaceable (Double wear rings available)
- **Seal:** Cornell's patented Cycloseal® design with Run-Dry™ oil lubrication system. John Crane T-2 single mechanical seal with Viton® elastomers, stainless steel hardware and tungsten- vs. siliconcarbide seal faces for abrasion resistance
- **Shaft Sleeve:** Heat treated 416 stainless steel
- **Bearings:** Heavy duty, grease lubricated, deep groove ball bearings, with a minimum of 20,000 hours bearing life

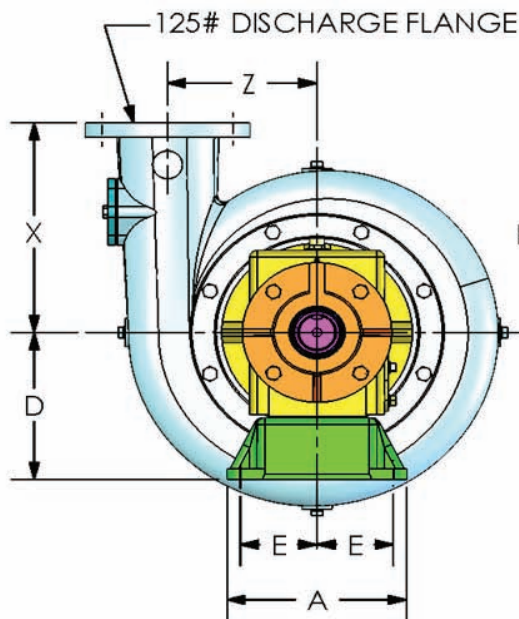

A typical picture of the pump is shown. Please contact Cornell Pump Company for further details. All information is approximate and for general guidance only.



10NHTB-F

DATA SHEET



LA20527

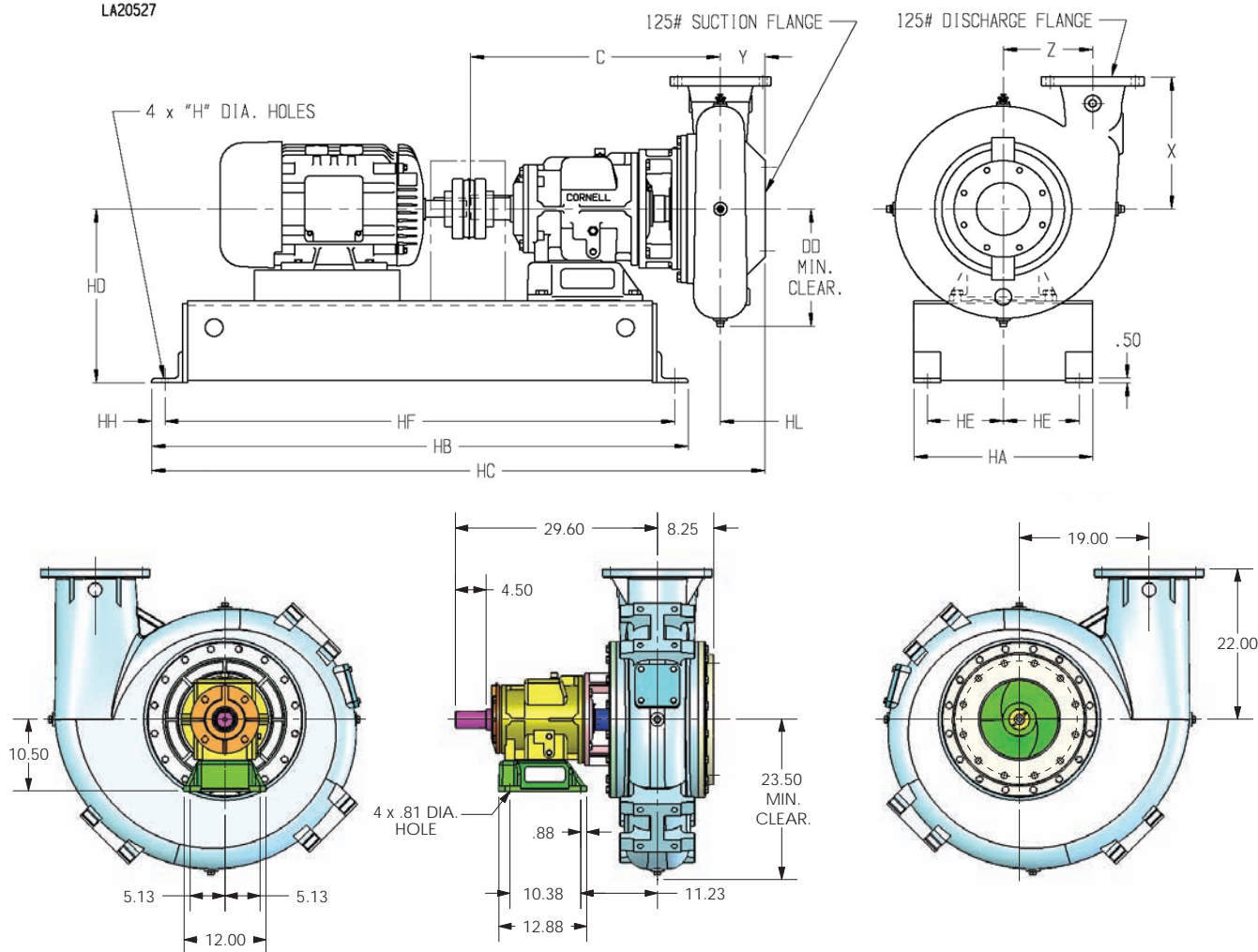

11/02/12

