



Efficient by Design

6SJ15-F

SELF PRIMING TRASH PUMP



PRODUCT CAPABILITIES

Size	6" x 6"
Capacities To	1700 GPM
Total Dynamic Heads	205 Ft.
Solids Handling	2" Dia
Repriming Lifts To	25 Ft.
Flanges	2" ANSI 150lb
Impeller	Semi-open, 4 Vane Trash Handling
Approx. Weight	895lb
Bearing Housing	Heavy Duty Ball Bearings - grease lubricated
Mounting Options	Pedestal Frame Mount, Base Mount

- ✓ Shimless impeller clearance adjustment
- ✓ Easily removable coverplate
- ✓ Back pullout rotating assembly
- ✓ Atmospheric barrier and lip seal
- ✓ Volute passes full solid size
- ✓ Exclusive rubber lined wear plate
- ✓ Easily replaceable suction check valve
- ✓ Heavy duty bearings
- ✓ Heavy duty castings
- ✓ Solids handling impeller
- ✓ Silicon-Carbide seal w/ grease lubrication
- ✓ Rapid Self-Priming
- ✓ No need for discharge check valve
- ✓ Optional casing heater

MATERIALS OF CONSTRUCTION

Materials	All Iron Volute & Impeller or Hard Iron Fitted* or 316SS Fitted* or Bronze Fitted*
Shaft	4130 Steel or Duplex Stainless Steel*
Bearings	Pump End: Ball Bearing Drive End: Ball Bearing
Wear Plates	Abrasion resistant rubber or Stainless Steel* or Hardened Iron* or Bronze*
Gaskets	Buna, Paper or Viton*
Suction Check Valve	Viton or Nitrile Rubber
Mechanical Seal	Silicon-Carbide Seal w/ grease lubrication

*optional
Other material available

6SJ15-F SELF PRIMING TRASH PUMP

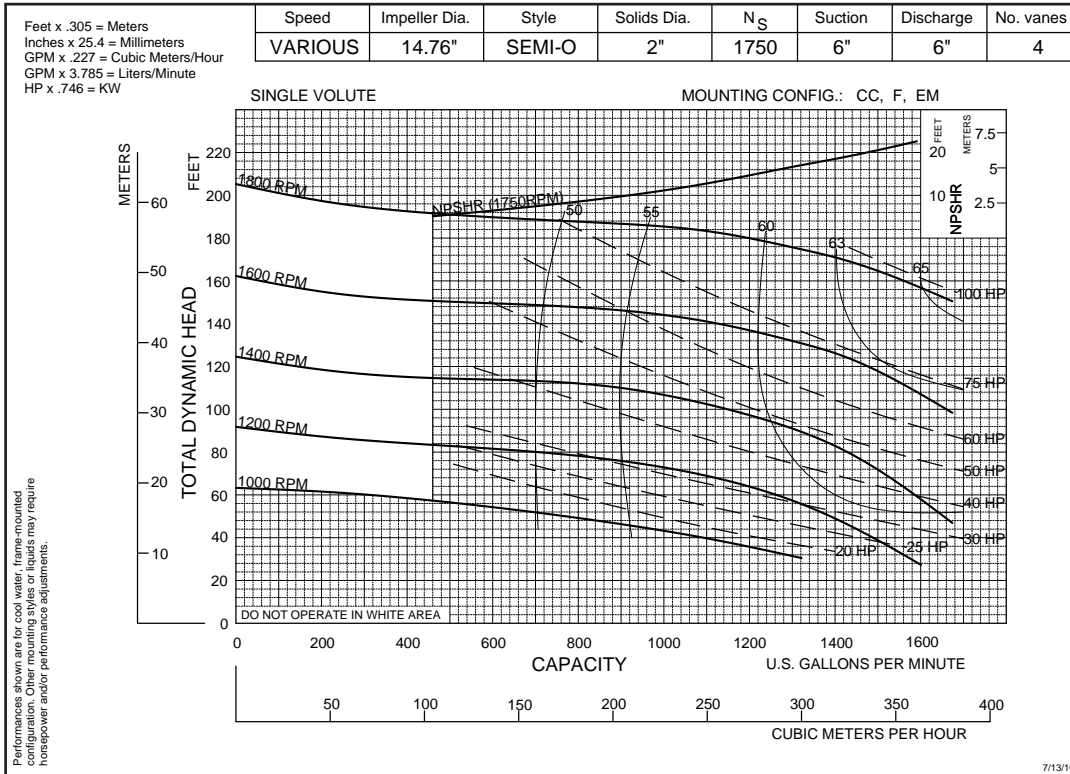

6SJ16 Flange

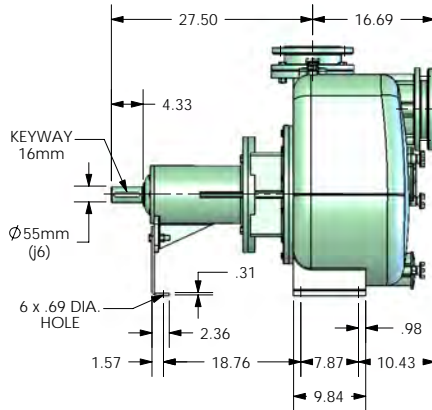

6SJ16 Flange

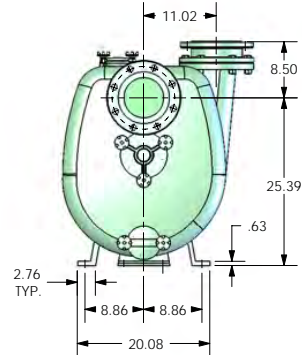

Other mounting configurations available