



Efficient by Design

3ST

SELF PRIMING TRASH PUMP



PRODUCT CAPABILITIES

Size	3" x 3"
Capacities To	520 GPM
Total Dynamic Heads	125 Ft.
Solids Handling	2.5" Dia
Repriming Lifts To	25 Ft.
Flanges	3" NPT or ANSI 125lb
Impeller	Semi-open, 2 Vane Trash Handling
Approx. Weight	420lb
Bearing Housing	Separate oil reservoir w/ dual bearing protection
Mounting Options	Pedestal Frame Mount, Engine Mount (SAE #4), Base Mount

MATERIALS OF CONSTRUCTION

Materials	All Iron w/ Ductile Iron Volute & Impeller or Hard Iron Fitted* or 316SS Fitted*
Shaft	4130HT Steel or Duplex Stainless Steel*
Bearings	Pump End: Ball Bearing Drive End: Dual Ball Bearing
Wear Plates	Oil resistant, rubber coated or Stainless Steel* or Hardened Iron*
Gaskets	Buna or Viton*
Pressure Relief Valve	Brass
Suction Check Valve	Canvas Reinforced Nitrile Rubber or Viton*
Mechanical Seal	Self aligning Silicon-Carbide Seal w. oil lubrication

- ✓ Shimless impeller clearance adjustment
- ✓ Easily removable coverplate
- ✓ Back pullout rotating assembly
- ✓ Dual protection of bearings
- ✓ Atmospheric barrier and dual lip seals
- ✓ Volute passes full solid size
- ✓ Exclusive rubber lined dual wear plates
- ✓ Easily replaceable suction check valve
- ✓ Heavy duty bearings
- ✓ Heavy duty castings
- ✓ Solids handling impeller
- ✓ Self aligning Silicon-Carbide seal w/ oil lubrication
- ✓ Rapid Self-Priming
- ✓ No need for discharge check valve
- ✓ Optional casing heater

*optional
Other material options available

3ST SELF PRIMING TRASH PUMP

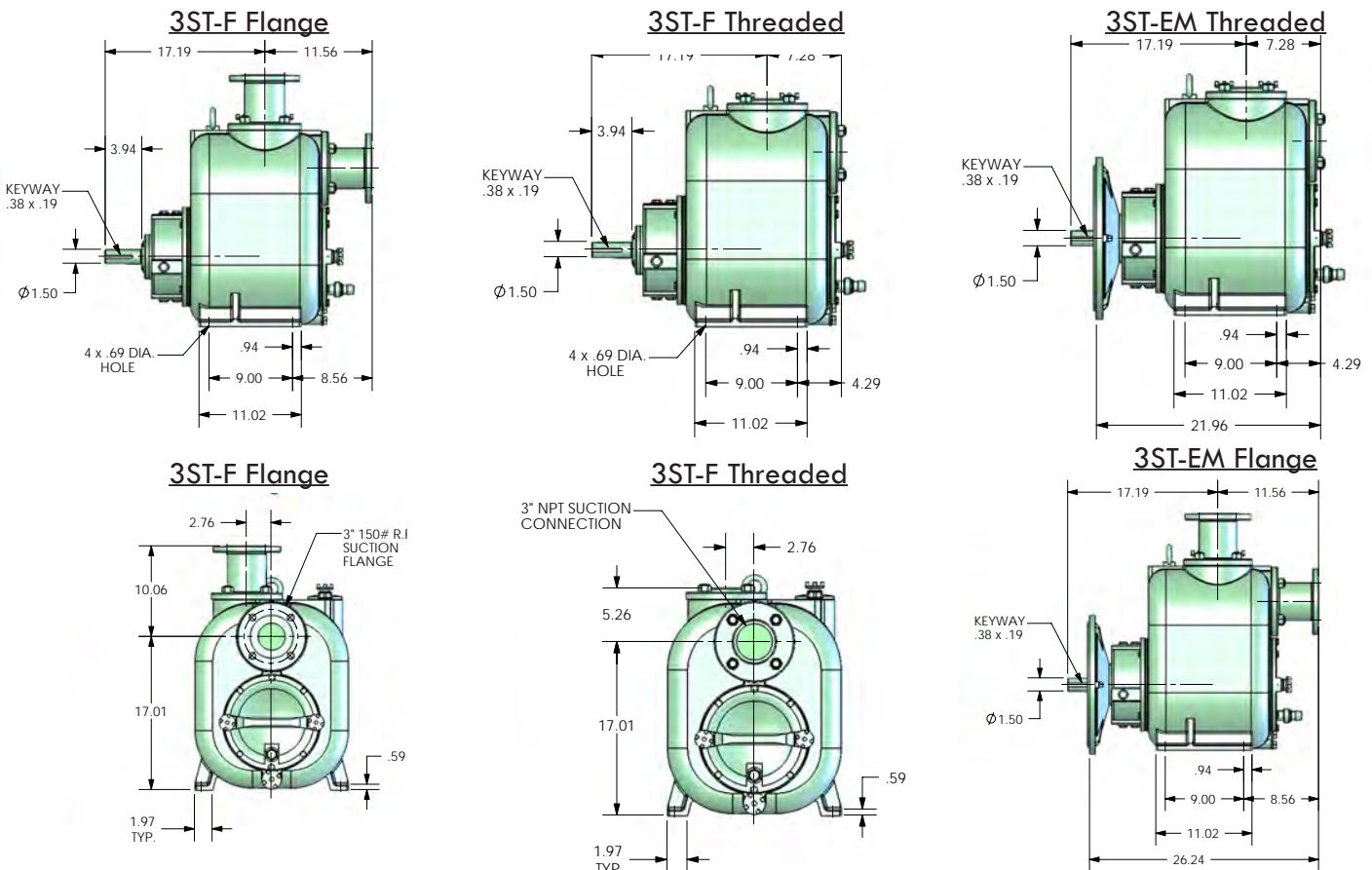
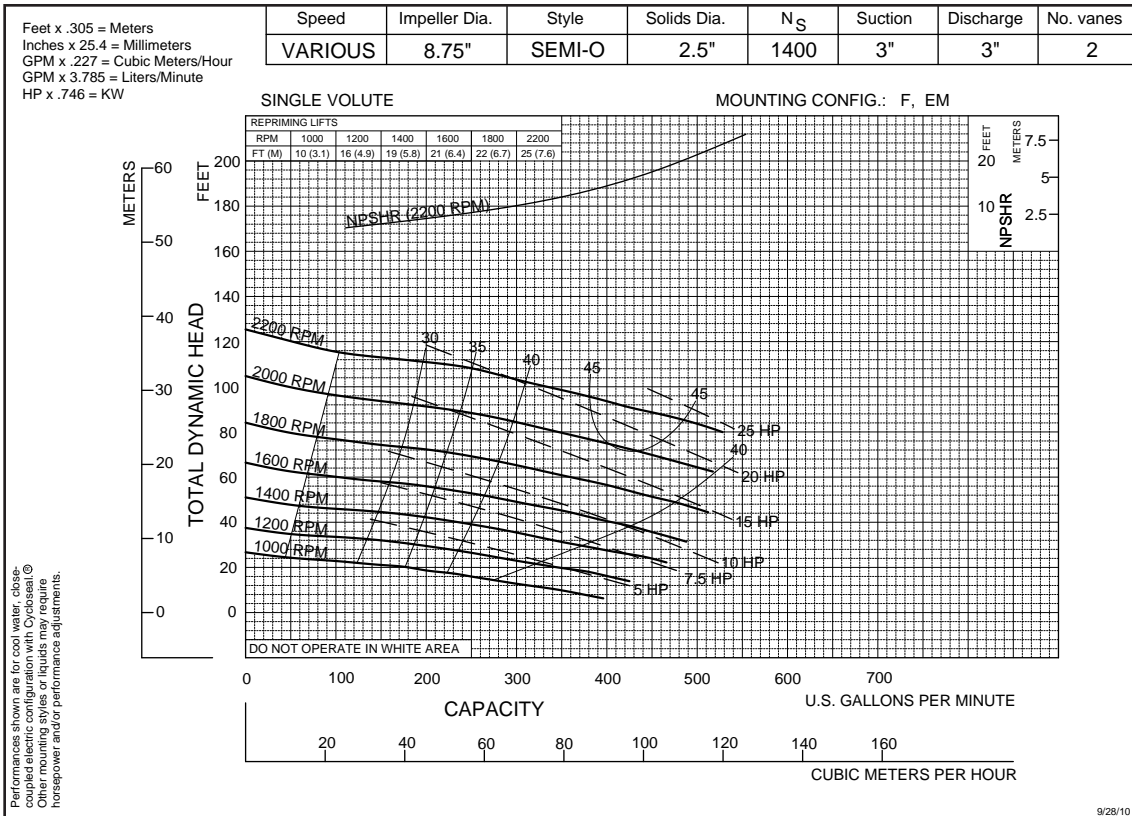

Other mounting configurations available