

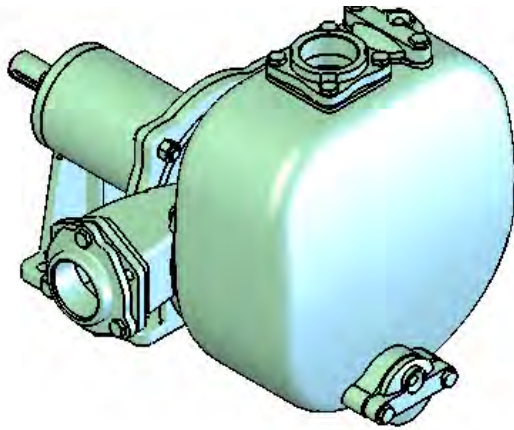

Efficient by Design

2SJ9-F

SELF PRIMING TRASH PUMP



PRODUCT CAPABILITIES

Size	2" x 2"
Capacities To	190 GPM
Total Dynamic Heads	280 Ft.
Solids Handling	.50" Dia
Repriming Lifts To	25 Ft.
Flanges	2" NPT or ANSI 150lb
Impeller	Semi-open, 5 Vane Trash Handling
Approx. Weight	123lb
Bearing Housing	Heavy Duty Ball Bearings - grease lubricated
Mounting Options	Pedestal Frame Mount, Base Mount

- ✓ Shimless impeller clearance adjustment
- ✓ Easily removable coverplate
- ✓ Back pullout rotating assembly
- ✓ Atmospheric barrier and lip seal
- ✓ Volute passes full solid size
- ✓ Exclusive rubber lined wear plate
- ✓ Easily replaceable suction check valve
- ✓ Heavy duty bearings
- ✓ Heavy duty castings
- ✓ Solids handling impeller
- ✓ Silicon-Carbide seal w/ grease lubrication
- ✓ Rapid Self-Priming
- ✓ No need for discharge check valve
- ✓ Optional casing heater

MATERIALS OF CONSTRUCTION

Materials	All Iron Volute & Impeller or Hard Iron Fitted* or 316SS Fitted* or Bronze Fitted*
Shaft	1040HT Steel or Stainless Steel* AISI 316
Bearings	Pump End: Ball Bearing Drive End: Ball Bearing
Wear Plates	Abrasion resistant rubber or Stainless, Iron Steel* or Hardened Iron* or Bronze*
Gaskets	Buna, Paper or Viton*
Suction Check Valve	Viton or Nitrile Rubber
Mechanical Seal	Silicon-Carbide Seal w/ grease lubrication

*optional
Other material available

2SJ9-F SELF PRIMING TRASH PUMP

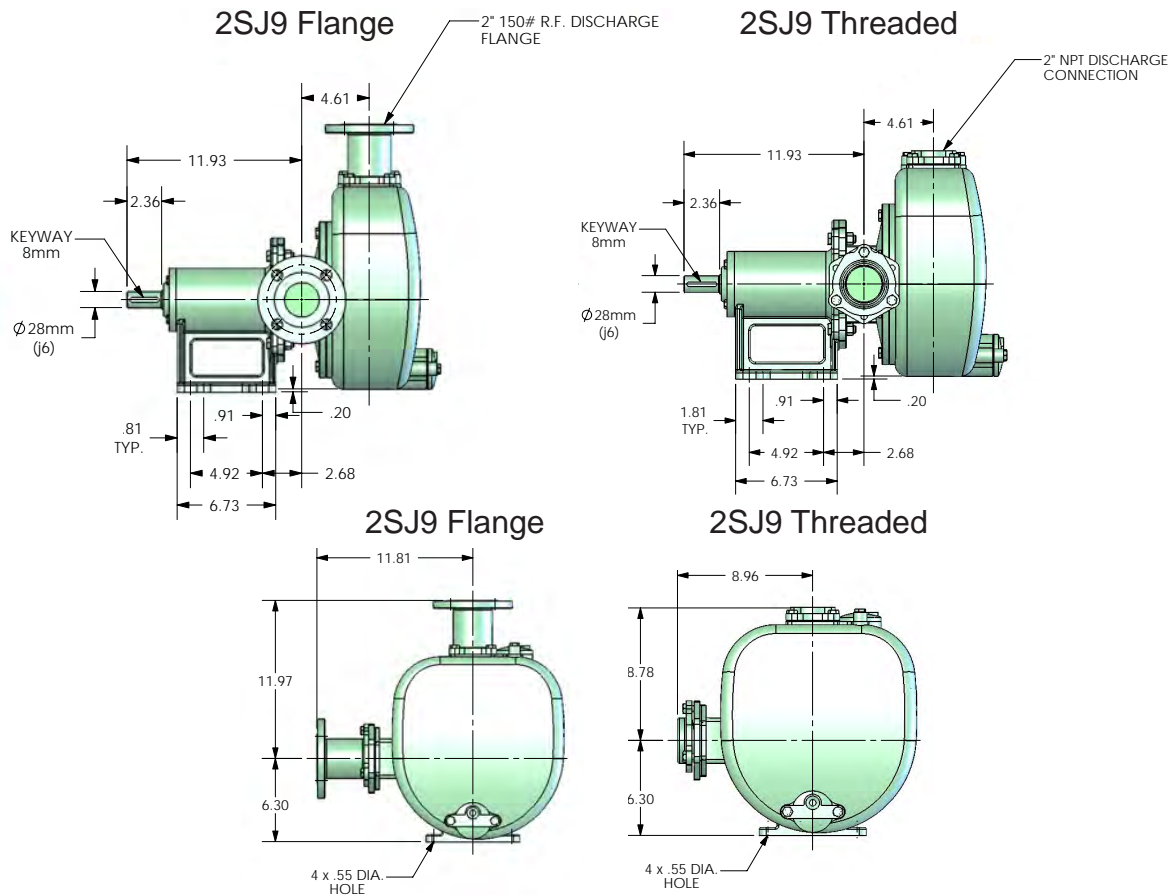
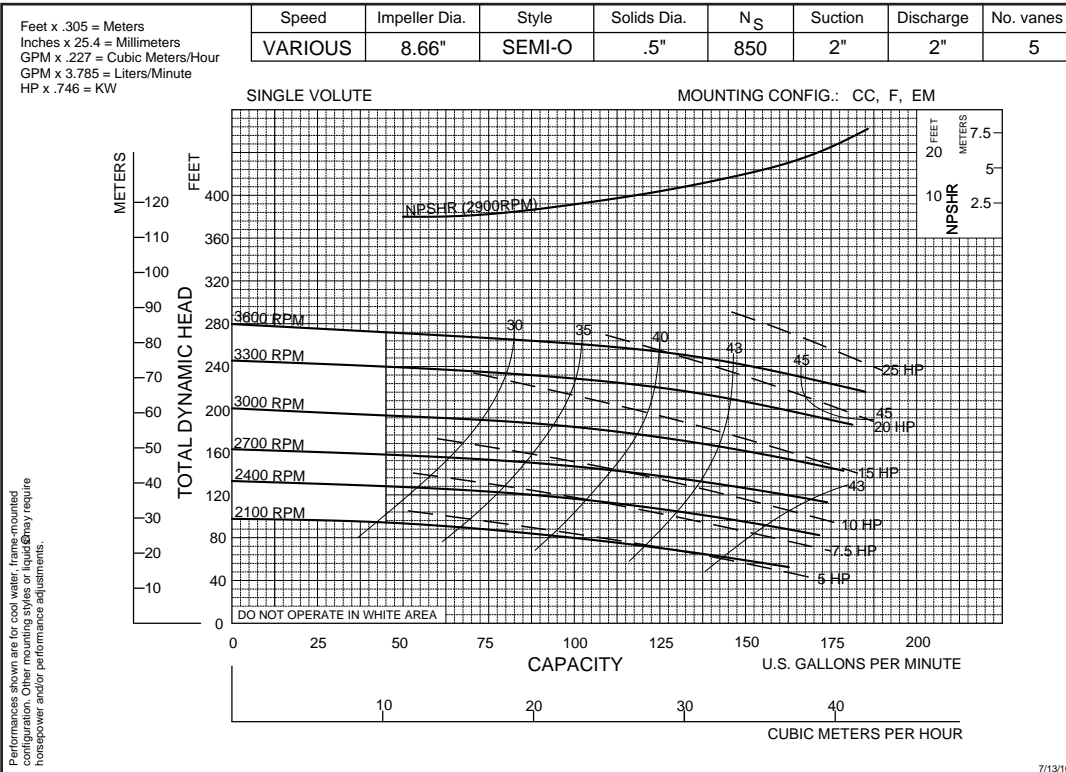

Other mounting configurations available