



CORNELL PUMP COMPANY

8NHPP Food Handling Pump

PUMP SPECIFICATION

- 8NHPP-F18K Frame mounted food handling pump
- 8" x 8" Class 125 Flanged suction and discharge
- Constructed of ASTM A48, Class 30 Cast Iron
- 16.38" impeller diameter
- 5" diameter by 9" length solid food handling characteristics
- Food grade packing
- Industry leading two year warranty
- Variable operating speed
- Optional mounting configurations available

FEATURES & BENEFITS

- **Cornell's Patented Pump Design**
 - significantly reduces product damage and abrasion
- **Single Port Impeller**
 - proven feature designed specifically for handling whole or processed foods
- **Offset Volute**
 - food passes through center of discharge nozzle without contacting volute wall
- **Cycloseal® Option**
 - self-contained single mechanical seal
 - requires no external flush
 - pressure gradients move solids away from seal faces
- **Quality Materials**
 - other materials of construction available for abrasive or caustic applications

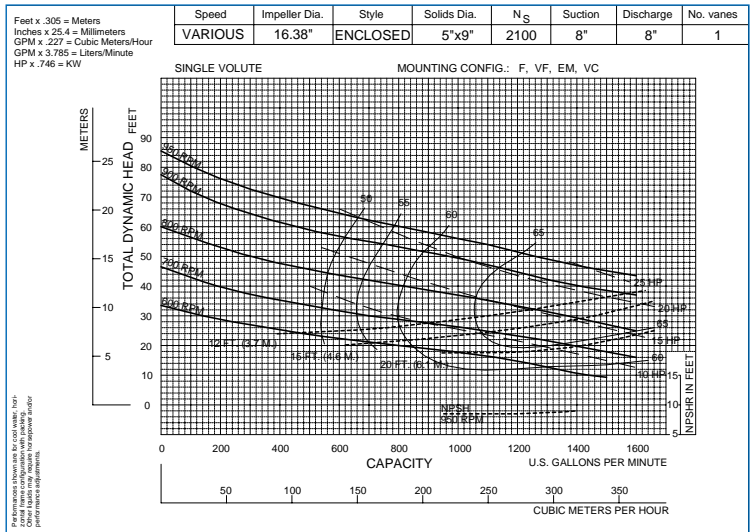
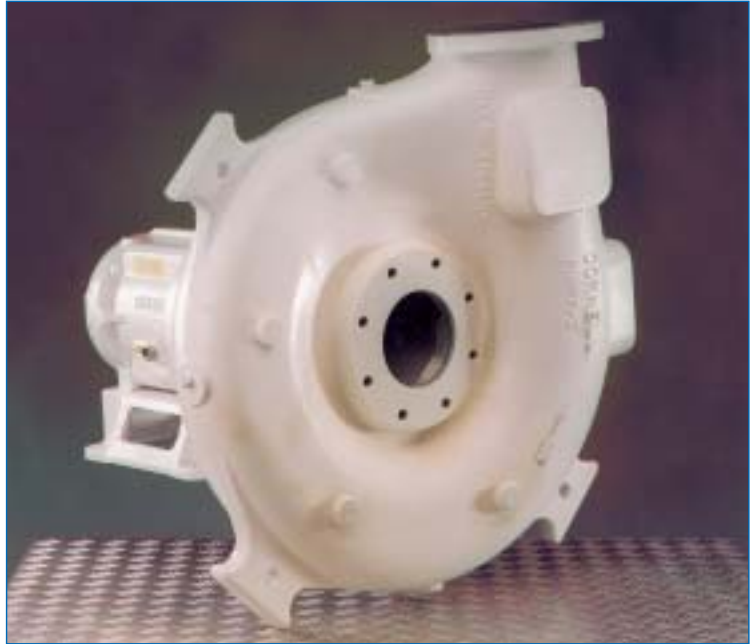

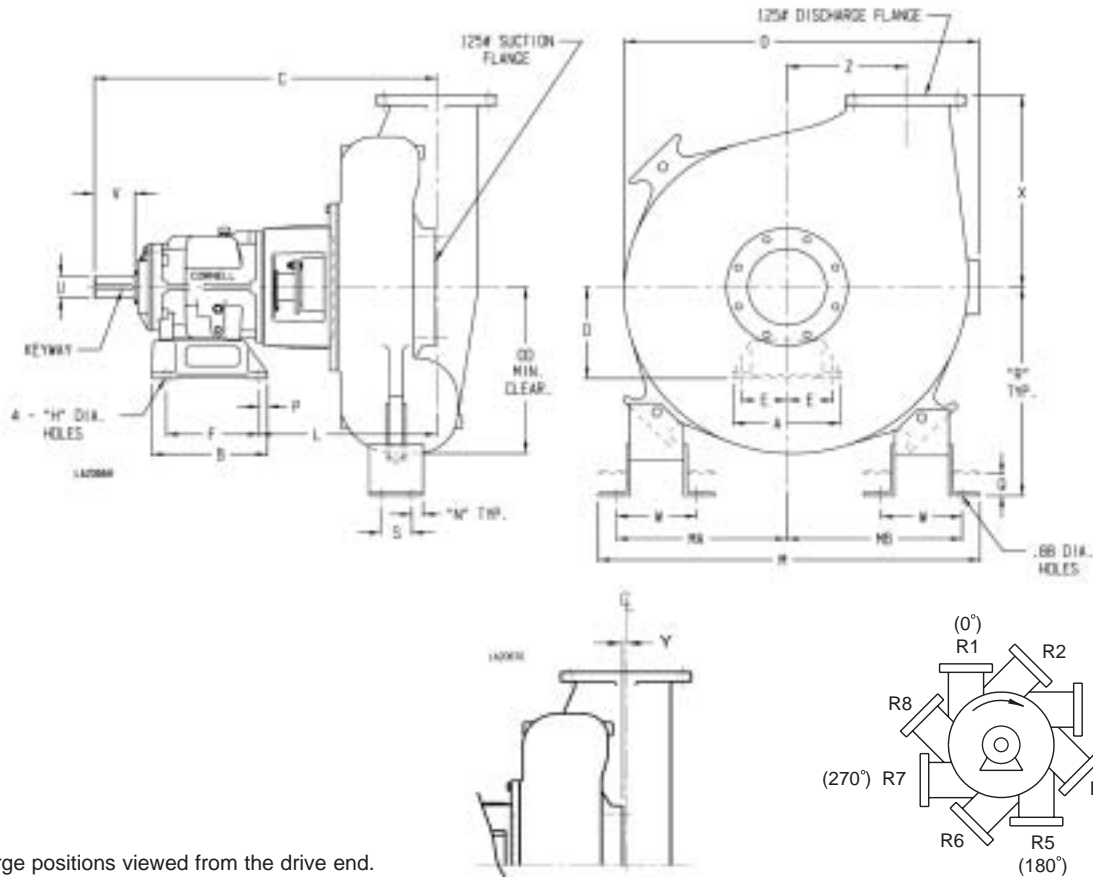

Detail A

Notes:

1. Discharge positions viewed from the drive end.
2. Consult factory for other discharge positions.

PUMP DIMENSIONS

Model	Frame	Connection		A	B	C	D	DD	E	F	H	L	M	MA
		Disch.	Suct.											
8NHPP	F18	8	8	12	12.88	38.06	10.5	20.38	5.12	10.38	0.81	19.69	42.38	18.88

PUMP DIMENSIONS (continued)

MB	N	O	P	Q	R	S	U	V	W	X	Y	Z	KEYWAY
19.5	1.25	39.5	0.88	2	24	3.5	2.5	4.5	9	22	.19*	13.25	.62 X .31

* See detail A for "Y" dimension

Notes:

1. Dimension "Q" is maximum adjustment for field weld.
2. "V" dimension is maximum useable shaft.
3. Frame mounting foot thickness is .75".
4. Dimension "DD", "M", "MA", and "R" shown are for top vertical position only.
5. Flange connection dimension can vary $\pm .12$ inch.
6. Do not use for construction unless certified.

Cornell Pump Company
 P.O. Box 6334
 Portland, Oregon 97228-6334
 Web: www.cornellpump.com
 Phone (503) 653-0330 • Fax (503) 653-0338