



# CORNELL PUMP COMPANY

## Refrigerant Pump 2HT Semi-Hermetic

### PUMP SPECIFICATION

- 2HT Semi-Hermetic, close-coupled refrigerant pump
- 4" x 2" Class 150 Flanged suction & discharge
- 250 PSIG Maximum Working Pressure
- Constructed of ASTM A536 60-40-18 Ductile Iron
- Industry leading three year warranty
- Four pole (1800/1500RPM) operating speed
- **Motor Specification:**
  - Totally enclosed Liquid Cooled
  - 3/4" Flanged liquid coolant recirculation connection with NPT tap
  - Varied voltages available
  - Stainless Steel motor liner
  - 200°C Thermal protection
  - Secondary containment
  - Replaceable hydrodynamic carbon motor bearings



### FEATURES & BENEFITS

- Semi-Hermetic technology allows the pump to operate without the need for a mechanical shaft seal
- **NPSHR**
  - Exceptional NPSHR characteristics
  - Characteristics are enhanced throughout entire operating range due to the single stage impeller and four pole operating speed
- **Vapor Handling**
  - Enhanced vapor handling abilities due to single stage impellers with large eye areas

Speed	Impeller Dia.	Style	Solids Dia.	N <sub>S</sub>	Suction	Discharge	SG
1760	VARIOUS	ENCLOSED	.37"	697	4"	2"	1.0

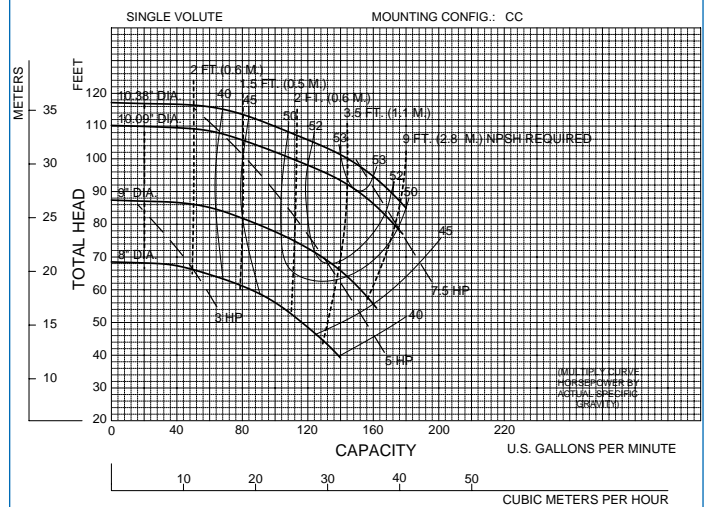

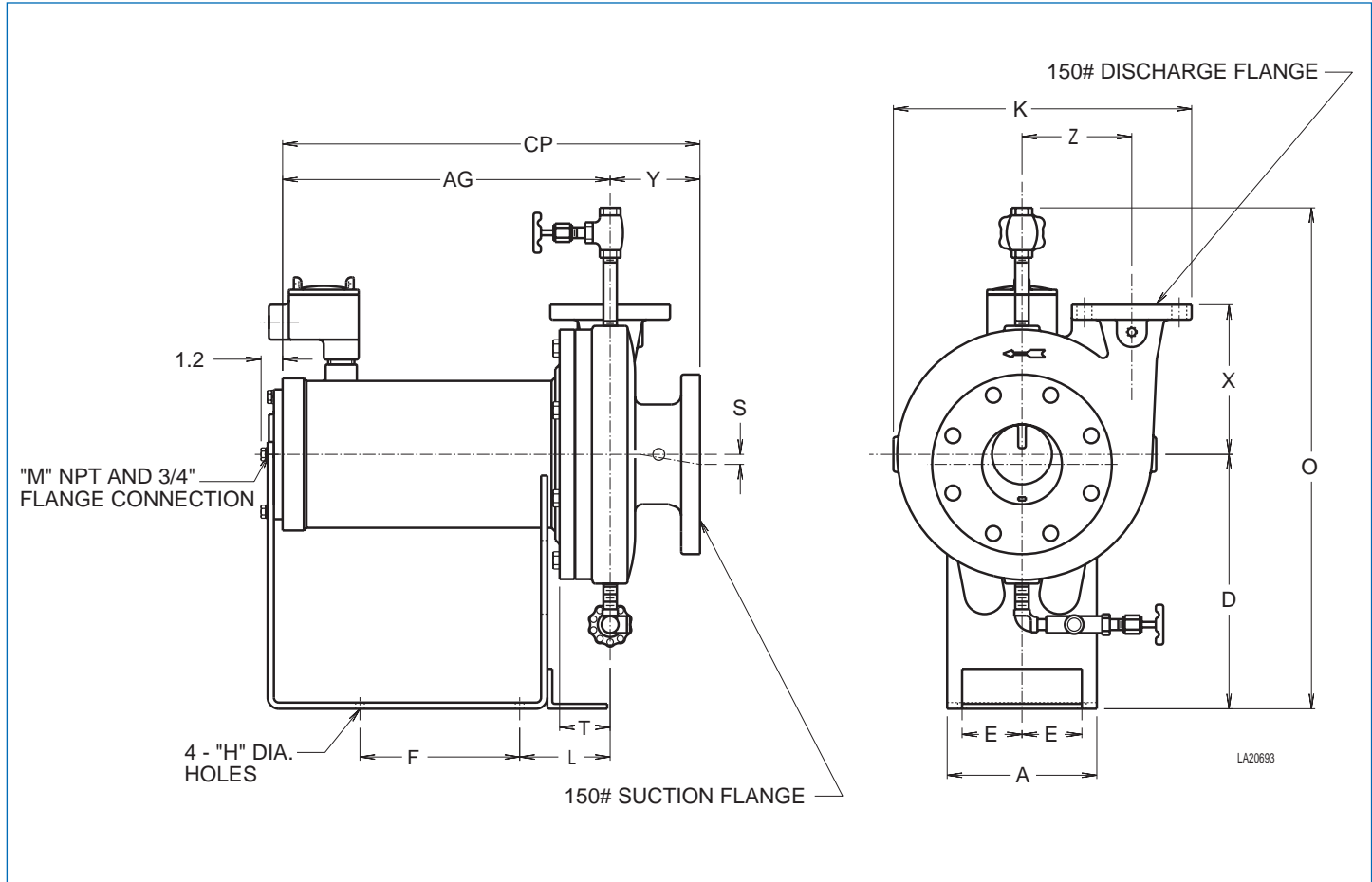

- Notes:**
1. Flange connection dimension can vary  $\pm .12$  inch.
  2. Do not use for construction unless certified.
  3. Overall dimensions can vary  $\pm .12$  inch.

### PUMP DIMENSIONS

Model	HP	RPM	Disch	Suct.	A	AG	CP	D	E	F	H	K	L	M	S	O	T	X	Y
1.5HT	5	1800	1.5	4	7.50	15.38	20.12	11	3	8	0.44	17.75	4.5	0.75	0.5	25.16	2.75	8	4.75
	7.5	1800	1.5	4	7.50	16.38	21.12	12.75	3	8	0.44	17.75	4.5	0.75	0.5	26.91	2.75	8	4.75
	15	1800	1.5	4	8.25	18	22.75	12.75	3.38	10	0.75	17.75	4.5	0.75	0.5	26.91	2.75	8	4.75
2HT/2HTS	3	1800	2	4	7.50	14	18.50	11	3	8	0.44	15	4.5	0.75	0.5	23.35	2.50	7.5	4.5
	5	1800	2	4	7.50	15.50	20	11	3	8	0.44	15	4.5	0.75	0.5	23.35	2.50	7.5	4.5
2.5HT	10	1800	2.5	5	9.50	17.88	23.38	13.75	4	10	0.75	19.25	5	0.75	0.61	27.85	2.62	9	5.5
	15	1800	2.5	5	9.50	18.88	24.38	13.75	4	10	0.75	19.25	5	0.75	0.61	27.85	2.62	9	5.5
3HT	10	1200	3	6	10.50	18.75	25.75	13.75	4.50	10	0.75	22.50	6	0.75	0.44	29.50	3.50	10	7
	15	1200	3	6	10.50	19.75	26.75	14.50	4.50	10	0.75	22.50	6	0.75	0.44	29.50	3.50	10	7

**Cornell Pump Company**  
 P.O. Box 6334  
 Portland, Oregon 97228-6334  
 Web: [www.cornellpump.com](http://www.cornellpump.com)  
 Phone (503) 653-0330 • Fax (503) 653-0338