

CORNELL PUMP COMPANY

Quality Choices Dependable Solutions

Refrigeration Pumps

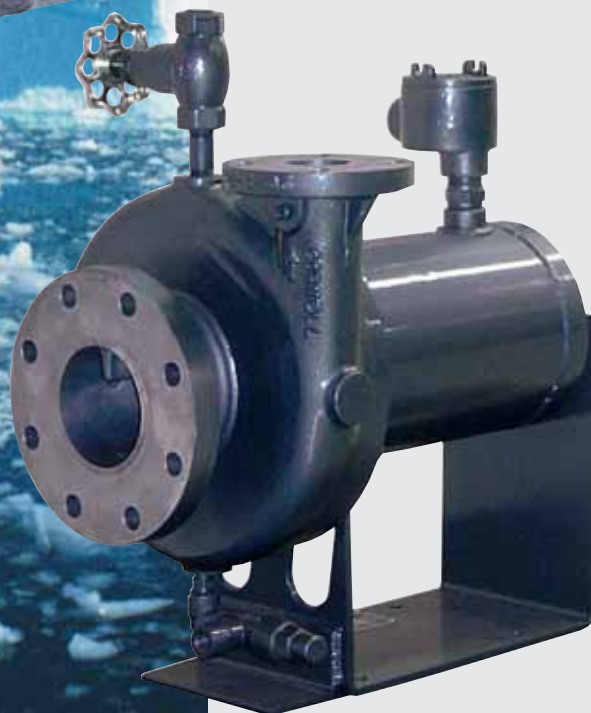

REFRIGERATION

Cornell understands the important role liquid overfeed and transfer pumps play in today's industrial refrigeration marketplace. Cornell's innovative Technologies provide the end-user with a containment system capable of continuous and reliable operation.

At Cornell, we've built our worldwide reputation on quality and reliability. Our centrifugal pumps are engineered and manufactured to provide reliable and trouble-free operation. Many Cornell liquid overfeed and transfer pumps sold in the 60's are still providing the same continuous and dependable service they did

the day they were installed. No one is more committed to making your ownership a truly rewarding experience than Cornell.

"Superior vapor handling characteristics."

Product Interchangeability: Close-coupled CB and hermetic HT pumps are dimensionally interchangeable with their corresponding sister pumps and with some competitive hermetic pump lines.

Cornell Standard Series	Cornell Hermetic Series
1.5CBH-5-4	Dimensional interchangeability with 1.5HT-5-4
1.5CBH-7.5-4	Dimensional interchangeability with 1.5HT-7.5-4
2CB/CBS-3-4	Dimensional interchangeability with 2HT/HTS-3-4
2CB/CBS-5-4	Dimensional interchangeability with 2HT/HTS-5-4
2.5CBH-10-4	Dimensional interchangeability with 2.5HT-10-4
2.5CBH-15-4	Dimensional interchangeability with 2.5HT-15-4
3CB-10-6	Dimensional interchangeability with 3HT-10-6
3CB-15-6	Dimensional interchangeability with 3HT-15-6

Proven Performance

Cornell's liquid overfeed pumps have been used successfully in a variety of applications including cold storage, food processing, refrigeration, ice production and turbine inlet cooling. Cornell refrigerant pumps are commonly employed in liquid overfeed and transfer pump applications utilizing anhydrous ammonia, aqueous ammonia, and halocarbons such as R-22 and other approved refrigerants.

CB Series - Ammonia

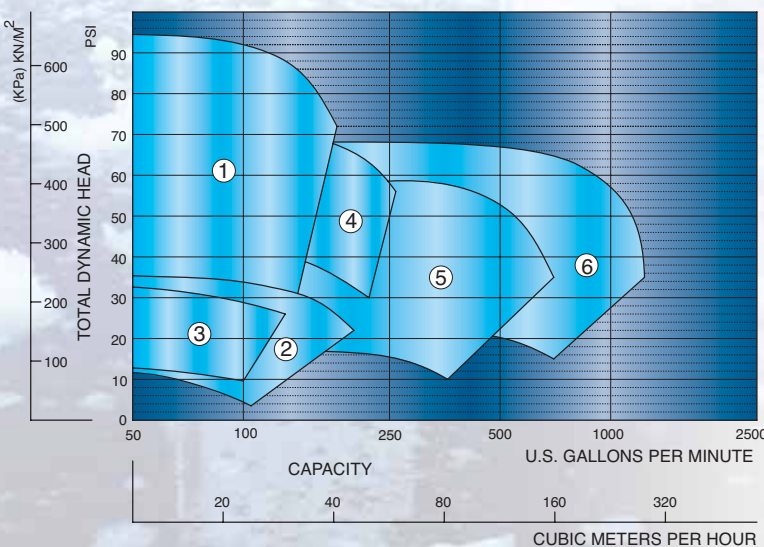

CB Series - Fluorocarbon

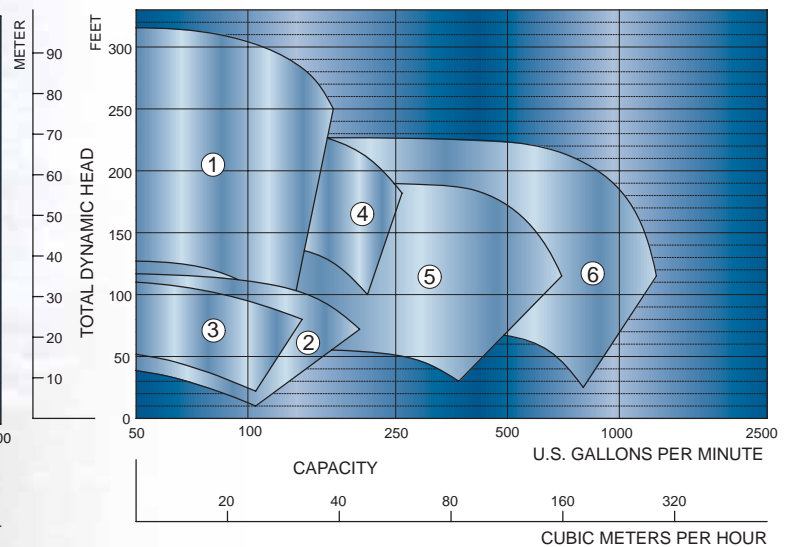

Ammonia or Fluorocarbon – 800-2200 RPM

- | | | |
|-----------|-----------|--------|
| 1. 1.5CBH | 3. 2CBS | 5. 3CB |
| 2. 2CB | 4. 2.5CBH | 6. 4CB |

LIQUID OVERFEED

Enhanced vapor handling and NPSHR characteristics are central to Cornell's latest liquid overfeed pump innovations. Cornell has incorporated these design features into our liquid overfeed pumps while maintaining two pole, four pole or six pole operating speed for close-coupled units. With the introduction of our refrigerant series of high head, low speed pumps, Cornell is working with our customers to address the increasing requirement for ultra-reliability and superior performance characteristics.

Cornell Has You Covered

The choice is yours: Cornell also offers hermetic style refrigeration pumps which have operating capabilities and dimensions similar to our standard CB pumps. The HT series is perfect for stable operating systems that have minimal vapor entrainment or cavitation issues. And with Cornell HT Series pumps you still get the advantage of low operating speed, better NPSH, experience, and an industry leading warranty.

Unattended Monitoring

The CB series sealing technology consists of an evolutionary double mechanical seal design with a pressurized barrier fluid reservoir, fluid level indicator and limit switch. This configuration allows for unattended monitoring of fluid level and a safety shut down feature. The HT series has an optional shut down feature when packaged with the Hansen Pump Guardian system. The Pump Guardian uses a pressure cutout if the pump starts cavitating. This feature prevents the bearings from running dry by shutting the pump down when cavitation is sensed.

"NPSHR of 1 foot has been achieved."

Comparison Curve and Chart

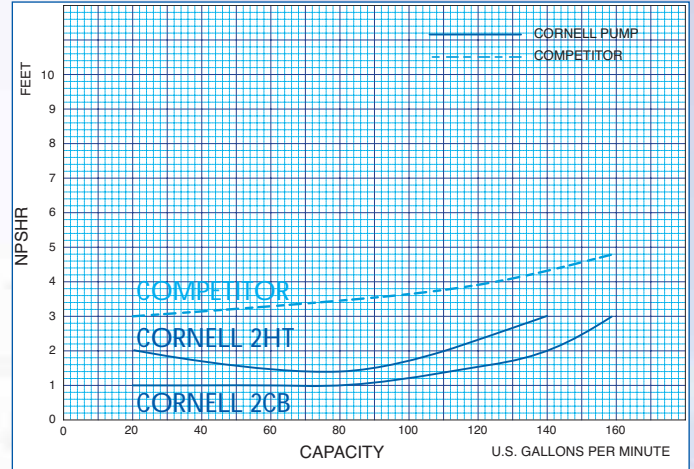

Cornell's 2CB and 2 HT have superior NPSHR.

HT Series - Ammonia

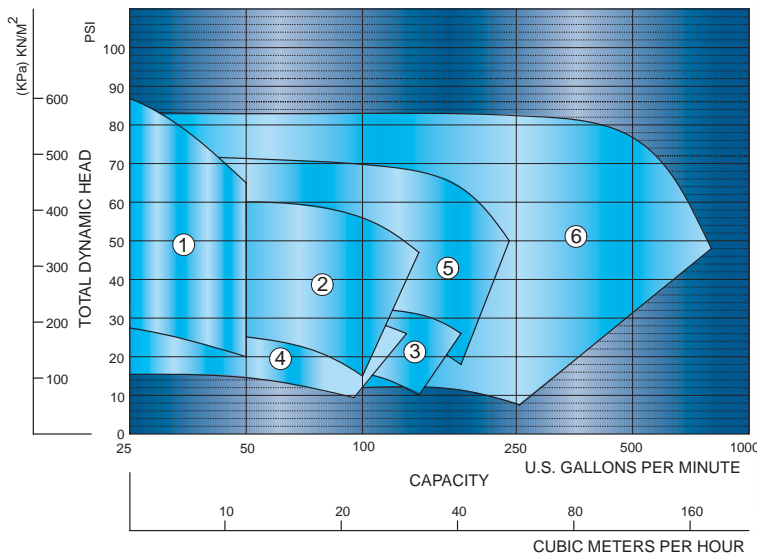

HT Series - Fluorocarbon

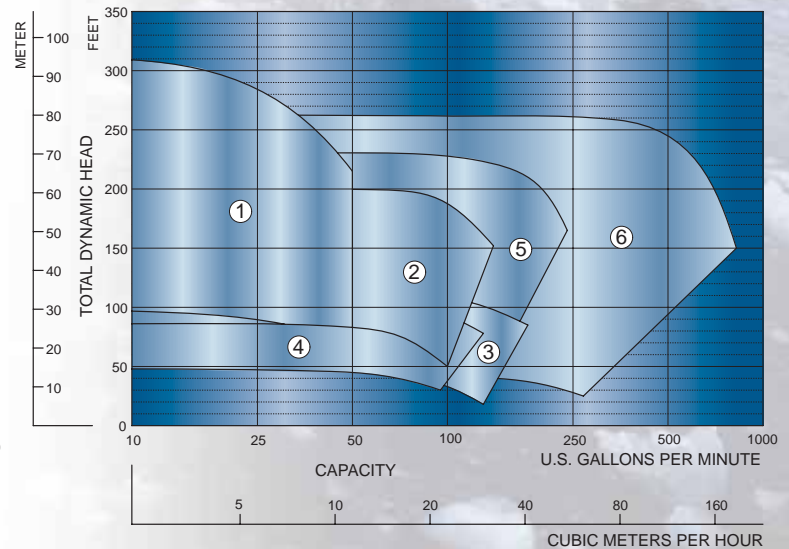

Ammonia or Fluorocarbon – 1000-3600 RPM

- | | | |
|---------------|---------|----------|
| 1. 1.25HT RPM | 3. 2HT | 5. 2.5HT |
| 2. 1.5HT RPM | 4. 2HTS | 6. 3HT |

FEATURES &

PRODUCT INTER

The HT and CB Series are c
with like models and simila
Quality Choices - D

CORNELL HERMETIC REFRIGERANT PUMP



SPECIFICATIONS

Hermetic, Close-coupled Refrigerant Pump:

- Class 150 Flanged suction and discharge
- 250 PSIG working pressure
- Constructed of ASTM A536 60-40-18 Ductile Iron
- Industry leading three year warranty
- Two pole (3000/3600RPM) operating speed
- Four pole (1800/1500RPM) operating speed
- Six pole (900/1200RPM) operating speed

Motor Specification:

- Totally enclosed, liquid cooled
- 3/4" Flanged liquid coolant recirculation connection with NPT tap
- Varied voltages available
- Stainless Steel motor liner
- 200°C thermal protection
- Secondary containment
- Replaceable hydrodynamic motor bearings
- Suitable for VFD applications

HERMETIC TECHNOLOGY

- Allows the pump to operate without the need for a mechanical shaft seal

NPSHR

- Exceptional NPSHR characteristics
- Characteristics are enhanced throughout the entire operating range due to the single stage impeller and 1800 RPM operating speed

Vapor Handling

- Enhanced vapor handling abilities



& BENEFITS

CHANGEABILITY

Dimensionally interchangeable
or in operating performance.
Dependable Solutions

CORNELL OPEN-DRIVE REFRIGERANT PUMP

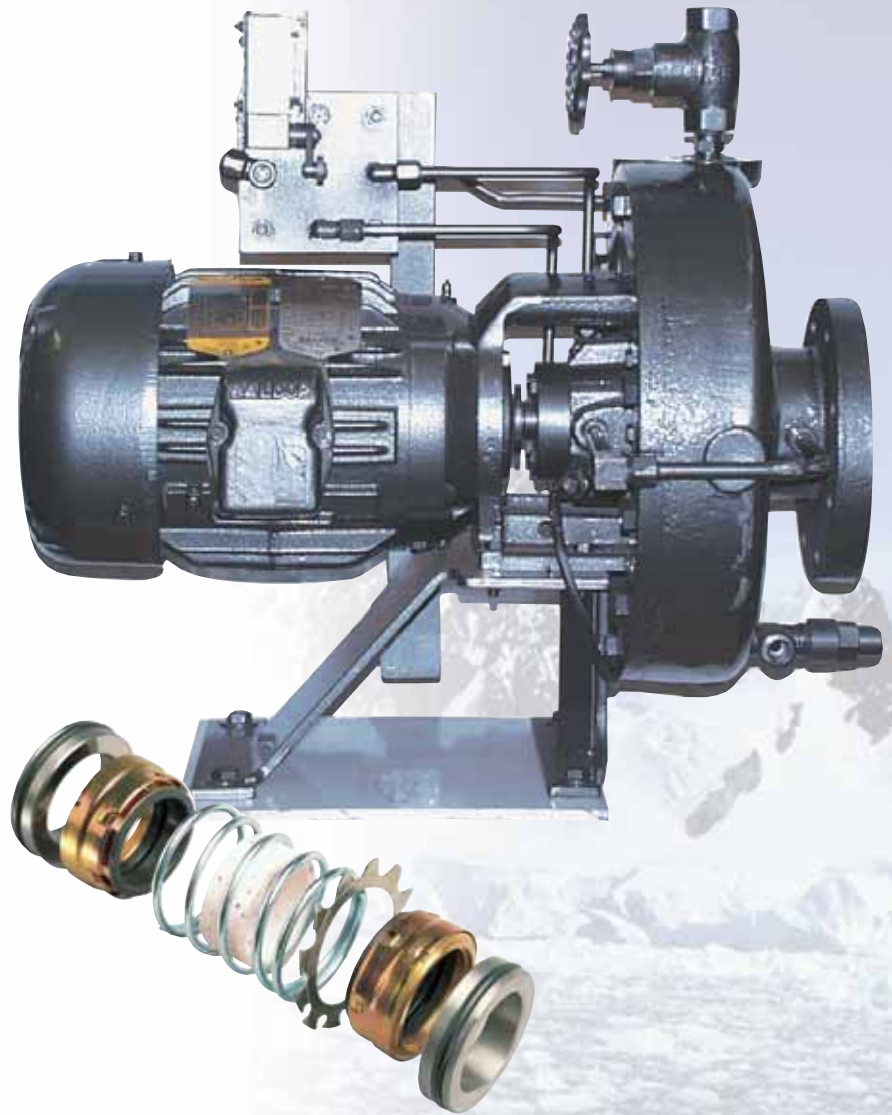

REFRIGERANT EMISSION FREE™ SEALING TECHNOLOGY

- A reliable system consisting of two mechanical seals mounted back to back
- Inboard seal prevents escape of refrigerant from the pump casing
- Outboard seal acts as a fail-safe or backup, and provides containment of a system compatible barrier fluid.

NPSHR

- Exceptional NPSHR characteristics
- Characteristics are enhanced throughout the entire operating range due to the single stage impeller and four pole operating speed

Vapor Entrapment

- Seals are oil lubricated, and do not rely on the presence of pumpage for lubrication or cooling
- The double mechanical sealing system allows the pump to continue to run until the system stabilizes and the pump re-primed itself – nuisance-tripping is avoided

SPECIFICATIONS

Close-coupled Refrigerant Pump:

- Class 150 Flanged suction and discharge
- 250 PSIG working pressure
- Constructed of ASTM A536 60-40-18 Ductile Iron
- Industry leading three year warranty
- Four pole (1800/1500RPM) operating speed
- Six pole (1800/1500RPM) operating speed
- Optional mounting configurations available

Mechanical Seal:

- Double mechanical shaft seal with pressurized barrier fluid lubrication system
- Low oil limit switch
- Seal chamber heater to maintain proper barrier oil viscosity

Motor Specification:

- Totally enclosed, fan cooled, refrigerant atmosphere, hostile environment, premium efficiency motor
- Class "F" insulation
- Suitable for VFD applications



COMMITMENT TO EXCELLENCE

Cornell Pump Company proudly maintains its ISO 9001:2000 certification which validates that Cornell is in compliance with all necessary processes to meet customer requirements.

The elements associated with ISO 9001:2000 certification include such areas as contract review, design and development, production, purchasing, quality control and service.



Cornell's refrigeration product group is not limited to liquid overfeed pump applications. Our clear liquid pumps are frequently used in cooling tower, chilled water, glycol, brine, condenser spray tree and many other HVAC applications. Cornell's clear liquid pumps are constructed entirely of iron or cast iron and fitted with bronze components. Many optional metalurgies are also available. Standard features include fully machined impellers, heavy duty shafts with replaceable shaft sleeves, and peripheral wear rings.

Transfer Pump Applications

Cornell's refrigerant pumps are available for use in transfer applications and have been successfully used for compressor oil, liquid transfer systems, and booster pump applications. Whether you require a liquid overfeed or transfer pump, Cornell's engineers and technical sales personnel can provide you with expert application assistance.

Glycol Pump Applications

In many refrigeration applications, secondary coolants such as ethylene and propylene glycols and brines are used as heat transfer media. The glycol or brine is cooled by the primary refrigerant and used to transfer heat without changing state. Cornell's clear liquids handling pumps are commonly used to recirculate these secondary coolants. The clear liquid pumps are rugged, extremely efficient and designed specifically for a long life of service.

H-Series

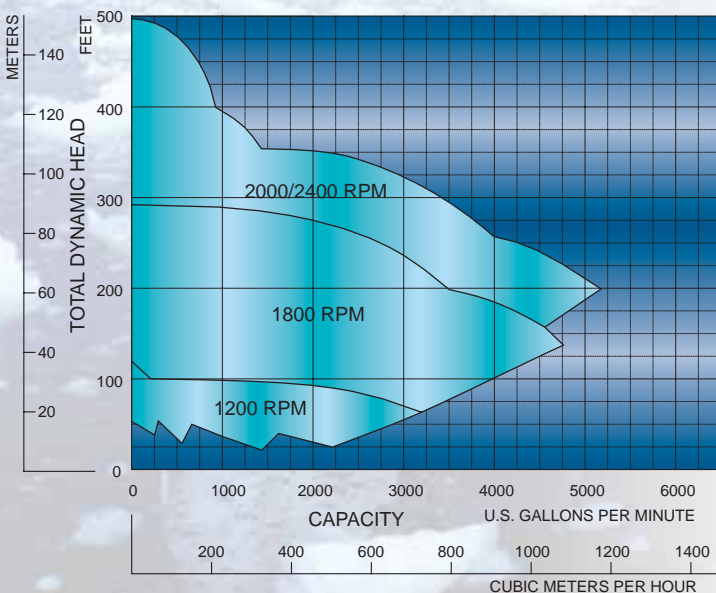

R-Series

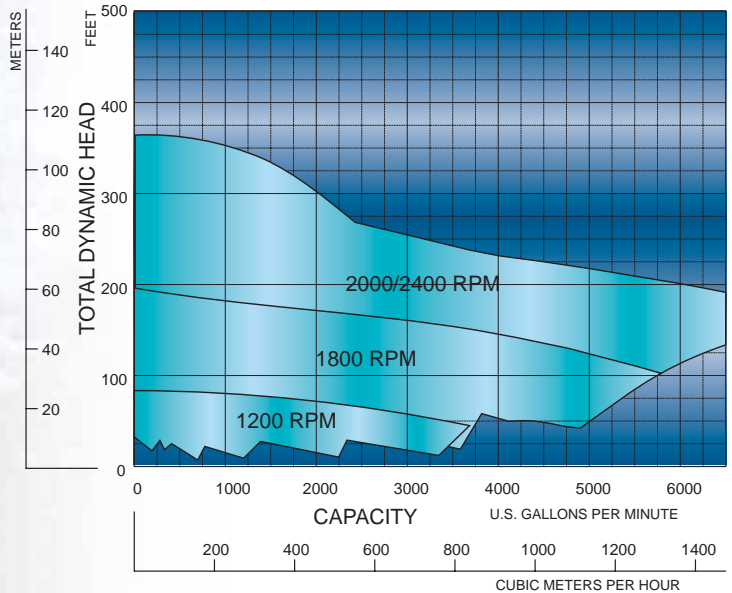

LIQUIDS

Energy Efficient Pumps

As energy costs rise, conservation and efficiency of operation become critical issues for end users striving to minimize expenses associated with energy consumption. Cornell pumps maintain superb hydraulic operating efficiencies and are coupled with energy efficient motors. The bottom line – Cornell pumps cost less to operate. Cornell Pumps are designed to deliver **best in class efficiency**. Depending on operating hours, fuelant, and horsepower required, you can save up to \$3,000 per year (or more) in energy costs. Cornell manufactures **more than 60 clear liquid and non-clog pumps** that meet or exceed optimum efficiency standards for centrifugal pumps.

Select High Efficiency Pump Models:	
8H	– 88% efficient
6RB	– 89% efficient
5RB	– 86% efficient
4RB	– 85% efficient

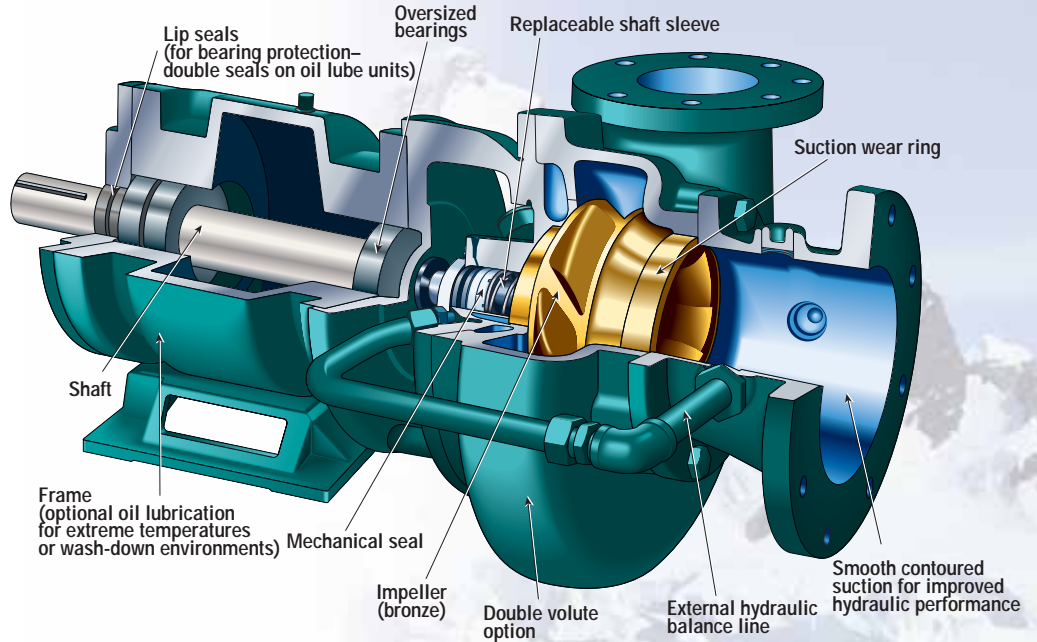

Mounting Configurations Available

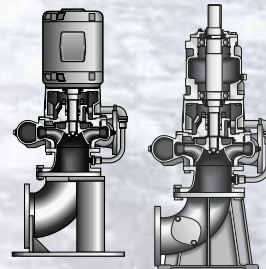
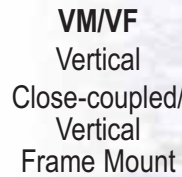
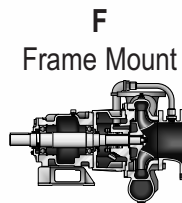
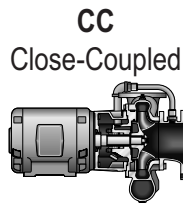

Y-Series

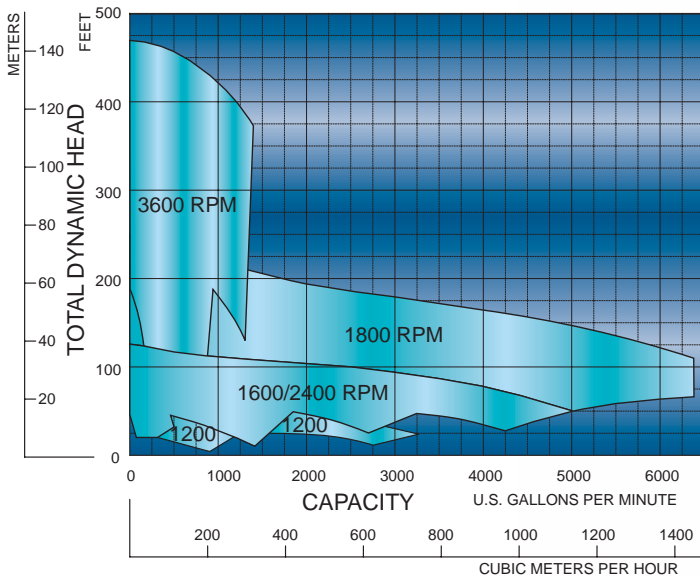

W-Series

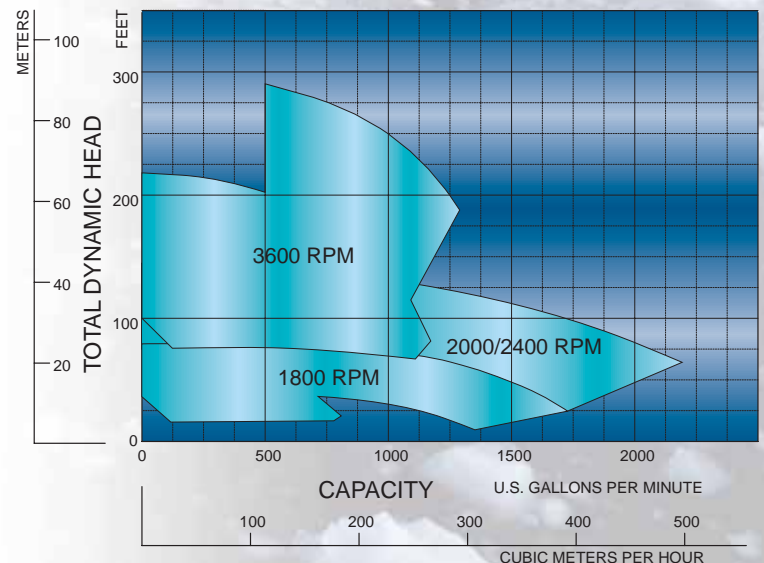



HANSEN



Cornell Pump Company

Portland, Oregon U.S.A.

Phone: (503) 653-0330
Fax: (503) 653-0338
Web: www.cornellpump.com

Hansen Technologies Corporation

Burr Ridge, Illinois U.S.A.

Phone: (630) 325-1565
Fax: (630) 325-1572
Web: www.hantech.com

Cycloseal® and Redi-Prime® are Registered Trademarks of Cornell Pump Company.

Cornell pumps and products are the subject of one or more of the following U.S. and Foreign patents: 3,207,485; 3,282,226; 3,295,456; 3,301,191; 3,630,637; 3,663,117; 3,743,437; 4,335,886; 4,523,900; 5,489,187; 5,591,001; 6,074,554; 6,036,434; 6,079,958; 6,309,169; 2,320,742; 96/8140; 319,837; 918,534; 1,224,969; 2,232,735; 701,979 and are the subject of pending US and Foreign Patent Applications.

CERTIFIED TO **ISO 9001:2000**



The Cornell Product Line:

Agricultural



IRRIGATION & SLURRY

Industrial



PROCESSING



FOOD



REFRIGERATION

Municipal



WASTE WATER & CONSTRUCTION



HYDRO-ENERGY

All Markets



RENTAL